

Model
Type

Skyjack 4626 Scissor Lift

Work
Height
Length
Width
Lifting
Capacity
Machine
Weight
Power

9.92m

2.31m

1.17m

454kg

2,170kg

Battery



STANDARD FEATURES

- DC motor controller
- Drivable at full height
- Variable speed, rear two wheel hydraulic drive
- Dual holding brakes
- Proportional controls for drive and lift functions
- 4' (1.22 m) Roll out extension deck
- 24V DC power source
- Low voltage battery protection
- Up to 30% gradeability
- Solid rubber, non-marking tyres
- Pothole protection system
- 110V AC outlet on platform with GFI
- 28 mph wind rating (12.5 m/s)
- Tilt alarm with drive & lift cut-out
- All motion audible alarm
- Lanyard attachment points
- Operator horn
- Hinged railing system
- Forklift pockets and tie down/lift lugs
- Relay based control system
- SKYCODED™ colour coded and numbered wiring system
- Telematics ready

IPAF Category 3a

Do you hold a valid operator's licence?

The Powered Access Licence (PAL) Card is recognised worldwide as proof of platform operator training to the highest standard.

It is issued by the International Powered Access Federation (IPAF) to platform operators who successfully complete a training course at an IPAF approved training centre.

Quick checklist for employers and operators using powered access machines:

- ✓ **I have an IPAF PAL card**
- ✓ **Date is still valid (Licence expires after 5 years)**
- ✓ **All categories for the machine's being used are listed on the PAL card (e.g. 3a, 3b, PAV).**

If you can answer yes to all three, you're good to go!

If not, please call us to discuss your requirements and arrange a training course.



Skyjack 4626 Scissor Lift

Dimensions	4626
A Work Height	9.92 m
B Raised Platform Height	7.92 m
C Lowered Platform Height	1.14 m
D Overall Width	1.17 m
E Overall Length	2.31 m
F Stowed Height (Rails Up)	2.15 m
G Stowed Height (Rails Down)	1.79 m
H Platform Width (Inside Dimension)	1.07 m
I Platform Length (Inside Dimension)	2.13 m

Specifications	4626
Extension Deck (Roll Out)	1.22 m
Ground Clearance (Stowed)	8.89 cm
Ground Clearance (Raised)	1.91 cm
Wheelbase	1.75 m
Weight	2,170 kg
Gradeability	30%
Turning Radius (Inside)	1.21 m
Turning Radius (Outside)	2.37 m
Lift Time (With Rated Load)	54 sec
Lower Time (With Rated Load)	32 sec
Drive Speed (Stowed)	3.2 km/h
Drive Speed (Raised)	1.1 km/h
Maximum Drive Height	Full Height
Lifting Capacity	454 kg
Distributed Capacity (Main Platform)	318 kg
Distributed Capacity (Extension Deck)	136 kg
Local Floor Load (With Rated Load)	1,544 kPa
Overall Floor Load (With Rated Load)	10 kPa
Maximum Persons (Indoor/Outdoor)	3/2
Tyre Type	Solid, N/M
Tyre Size	16 x 5 x 12

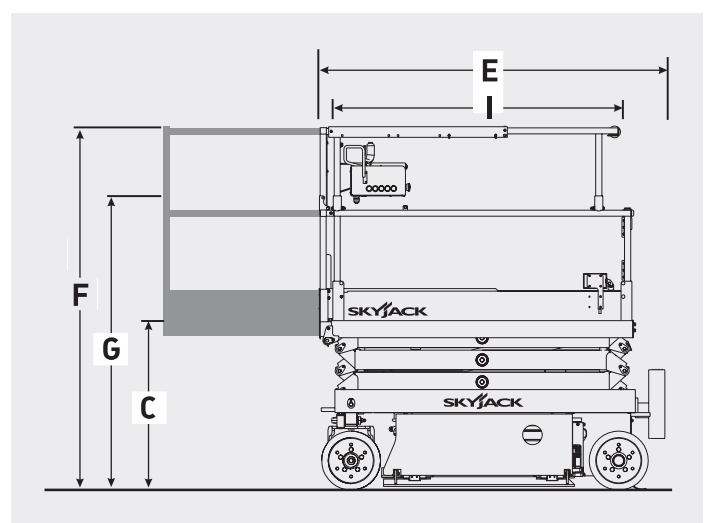
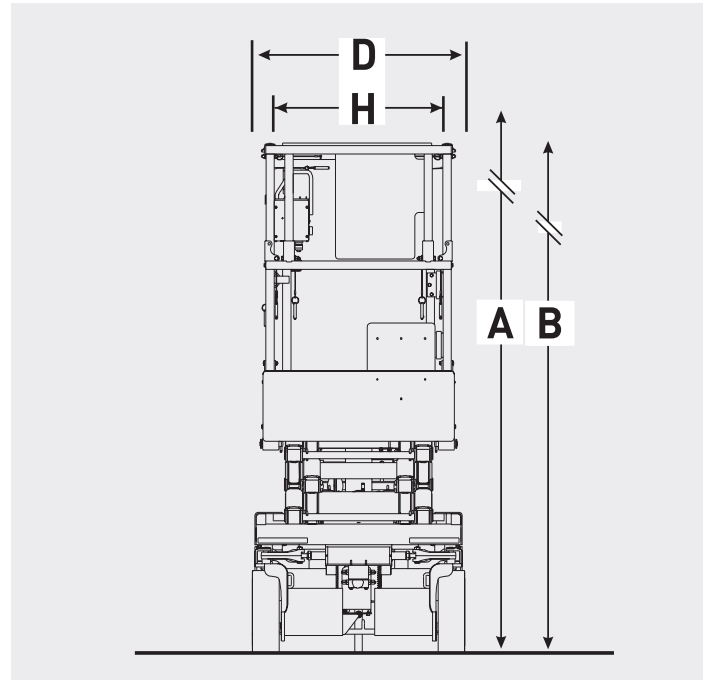

Special Features

- Skyjack's electrically powered scissor lifts offer a quiet, compact and versatile package with zero emissions, and are capable of manoeuvring in confined indoor and outdoor job sites and are suitable for a wide range of construction, maintenance and industrial applications
- Sturdy all steel design incorporates a manually operated roll out extension desk which increases work area and provides up-and-over capability
- Skyjack's unique clevis style design creates scissor ends that endure lower stress, and increased rigidity. This is achieved through symmetrical load distribution over the pins
- Removable, durable aluminium construction upper control box that's clear, intuitive, and easy to understand.

HIRE • SALES • TRAINING
0844 682 0000



**NATIONAL
COVERAGE**



We offer a true UK wide hire service via a network of strong regional access companies who share Star Platforms' values, offering high service levels and quality equipment.

For more information head to our website starplatforms.co.uk